

DESCALER

Protect your plumbing and household appliances from limescale buildup.

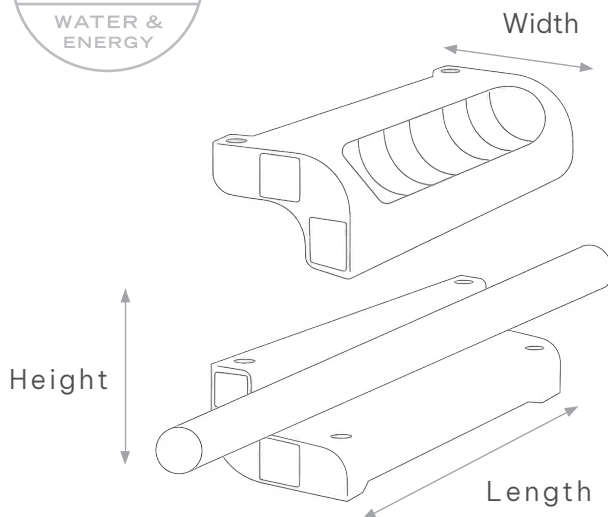

SAFETY WARNINGS

- Contains strong magnets. Keep away from electronics, credit cards, and magnetic storage media.
- Do not place near medical devices, such as pacemakers, defibrillators, or insulin pumps.

DIMENSIONS

Length:	115 mm
Width:	47 mm
Height:	53,5 mm
Weight:	250 g

MATERIAL

Casing:	ABS
Core:	Neodymium magnet

DESIGN

Simple, cost-effective solution for domestic and garden plumbing. Protects against limescale buildup, improves water quality, and extends the lifespan of your appliances.

FEATURES & FUNCTIONS

- + Reduces limescale formation and protects household appliances (washing machine, dishwasher, boiler, kettle) and garden systems.
- + Chemical-free and maintenance-free.
- + Easy installation on supply pipes up to 22 mm in diameter – no tools or system intervention required.
- + Eco-friendly and economical solution for conditioned water.
- + Enhanced efficiency of soaps and detergents due to treated water.
- + The magnetic field protects plumbing, appliances, and irrigation systems.